

C&K S2 Series Subminiature Thumbwheel Switches

Features/Benefits

- Front & rear mounting options available
- Variety of function codes
- Spacers available to fit most panel cutouts

Typical Applications

- Test & measurement equipment
- Instrumentation
- Computer peripherals

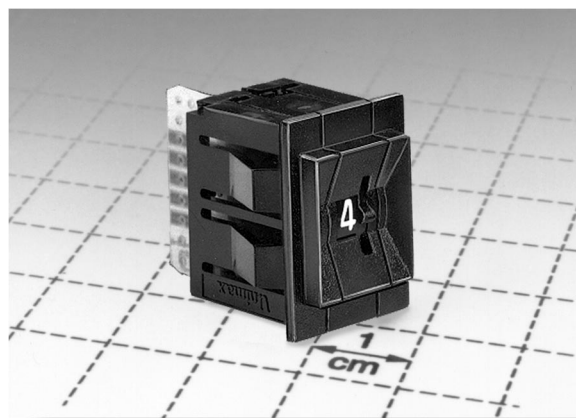

Build-A-Switch

Our easy Build-A-Switch concept allows you to mix and match options to create the switch you need. Below is a complete listing of options shown in catalog. To order, simply select desired option from each category and place in the appropriate box. Available options are shown and described on pages J-24 thru J-26. For additional options not shown in catalog, consult Customer Service Center.

Typical Example: **S 2 D** — **0 2 1** — **S** — **0** — **0**

Mounting Style

- S2D** Switch section only, no endplates
- S2F** Snap-in front mount
- S2R** Rear mount
- S2S** Rear mount
- S2T** Rear mount

Function Code

- 012** Decimal, SP, 10 position
- 018** Complement of BCD, 10 position
- 021** BCD, 10 position
- 054** Binary coded hexadecimal, SP, 16 position
- 057** Binary coded hexadecimal, SP, 16 position

Terminations

- S (STD.) PCB**
- A** Extended PCB
- C** PCB with solder pins
- E** Extended PCB
- L** Right angle
- P** Right angle

Color/Marking/Stops

- 0 (STD.) Black body & wheel, white marking**
- 9** Special body colors, wheel colors, marking and/or stops

Number of Sections

- 0** Switch section, no endplates
- 1** 1 Switch section
- 2** 2 Switch sections
- 3** 3 Switch sections
- 4** 4 Switch sections
- 5** 5 Switch sections
- 6** 6 Switch sections
- 7** 7 Switch sections
- 8** 8 Switch sections
- 9** More than 8 sections, specify on configuration form



Thumbwheel & Pushwheel

C&K S2 Series Subminiature Thumbwheel Switches

Specifications

CONTACT RATING:

CARRY: 3 AMPS continuous.

SWITCH: 0.4 VA max., 50 mA max., 50 V AC or DC max.

OPERATING VOLTAGE: 50 mV to 50 V AC or DC.

CONTACT RESISTANCE: Below 100 milliohms typ. @
2-4 V DC, 100 mA.

INSULATION RESISTANCE: 10^9 ohms min. (dry).

DIELECTRIC STRENGTH: 500 V RMS min. @ sea level
between common terminal and any output.

OPERATING TEMPERATURE: -40°C to 70°C .

Materials

HOUSING: Polycarbonate.

THUMBWHEEL: Acetal.

ROTOR CONTACTS: Precious metal on copper alloy.

STATOR CONTACTS: Hard gold over nickel over copper
on epoxy fiberglass.

NOTE: Specifications and materials listed above are general specifications for switches with standard options. For information on specific and custom switches, consult Customer Service Center.

MOUNTING STYLE

S2D SWITCH SECTION ONLY (ENDPLATES NOT SUPPLIED)



S2D021S00

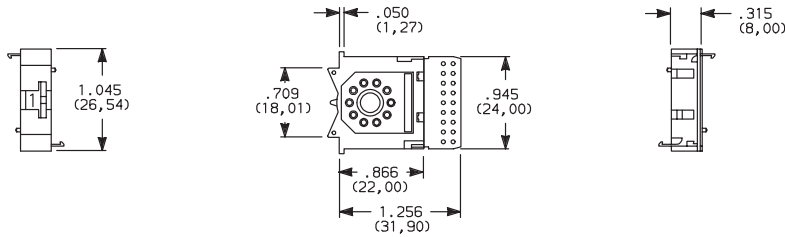

Must be ordered with 0 number of sections option, see page J-26.

S2F SNAP-IN FRONT MOUNT



S2F021S01

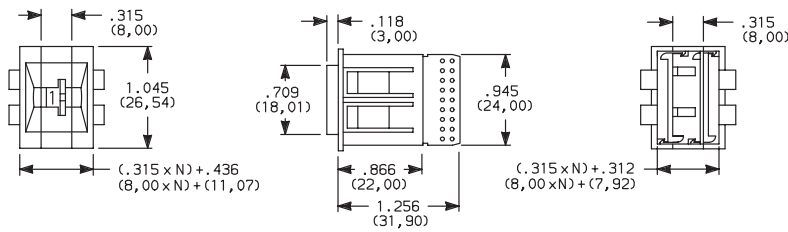

PANEL MOUNTING

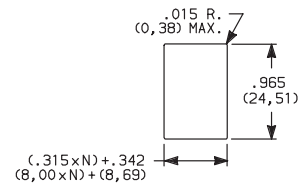

N = Number of sections.

Recommended panel thickness:
.046-.125
(1,16-3,18)

S2R REAR MOUNT (8MM FLANGE)

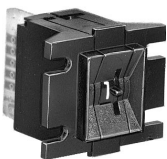

S2R021S01

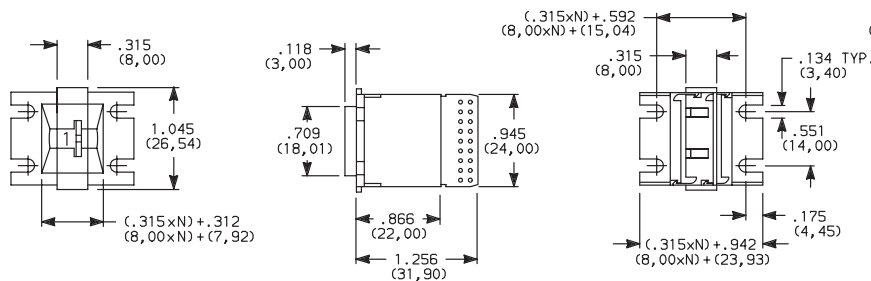

PANEL MOUNTING

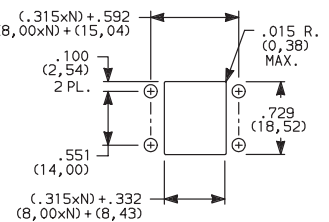

N = Number of sections.

Recommended panel thickness:
.046-.125
(1,16-3,18)

C&K S2 Series Subminiature Thumbwheel Switches

MOUNTING STYLE

S2S REAR MOUNT (4MM FLANGE)

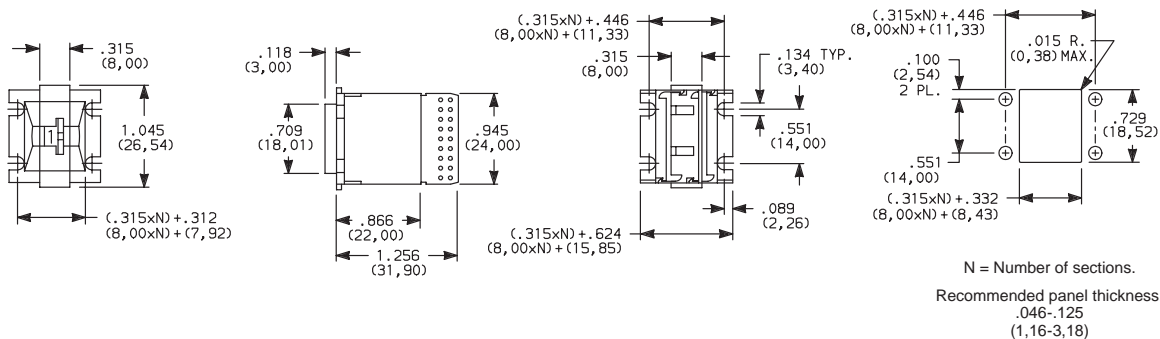

S2S021S01

S2T REAR MOUNT (NO FLANGE)

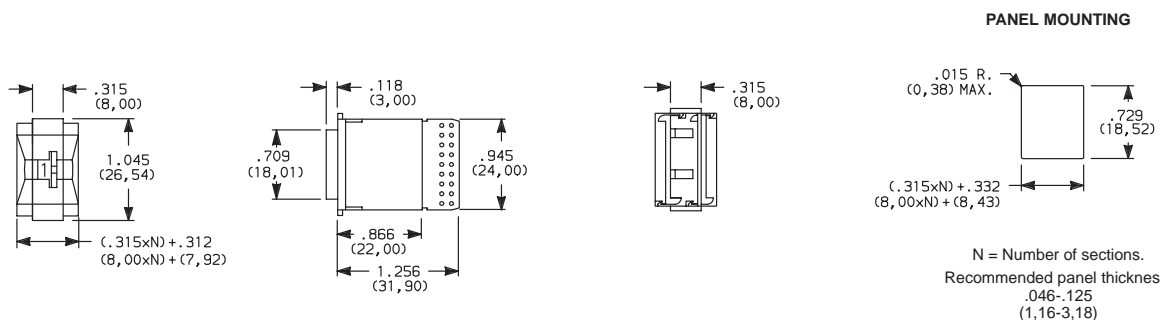

S2T021S01

FUNCTION CODE

012 DECIMAL SP, 10 POSITION

WHEEL	SIGNALS CONNECTED TO COMMON SIGNAL C										
	0	1	2	3	4	5	6	7	8	9	C
0	●										●
1		●									●
2			●								●
3				●							●
4					●						●
5						●					●
6							●				●
7								●			●
8									●		●
9										●	●
	1	2	3	4	5	7	8	9	10	11	6

TERM. LOCATION

Available Terminations: E, S
See fig. 2, page J-26.

018 COMPLEMENT OF BCD, 1-2-4-8, 10 POSITION

WHEEL	SIGNALS CONN. TO COMM. SIG. C				
	1	2	4	8	C
0	●	●	●	●	●
1	●	●	●	●	●
2	●	●	●	●	●
3	●	●	●	●	●
4	●	●	●	●	●
5	●	●	●	●	●
6	●	●	●	●	●
7	●	●	●	●	●
8	●	●	●	●	●
9	●	●	●	●	●
	4	5	6	7	3

TERM. LOCATION

Terminal locations for L or P termination options only.

Available Terminations: C, E, L, P, S
See figs. 1 & 3, page J-26.

021 BCD 1-2-4-8, 10 POSITION

WHEEL	SIGNALS CONN. TO COMM. SIG. C				
	1	2	4	8	C
0					●
1	●				●
2		●			●
3	●	●			●
4			●		●
5	●	●	●		●
6		●	●		●
7	●	●	●		●
8				●	●
9	●				●
	4	5	6	7	3

TERM. LOCATION

Terminal locations for L or P termination options only.

Available Terminations: A, C, E, L, P, S
See figs. 1 & 3, page J-26.

054 BINARY CODED HEXADECIMAL, SP, 16 POSITION, 0-9, A-F

WHEEL	054	057	SIGNALS CONN. TO COMMON SIG. C				
			1	2	4	8	C
0	0					●	
1	1		●			●	
2	2			●		●	
3	3		●	●		●	
4	4				●	●	
5	5		●	●	●	●	
6	6				●	●	
7	7		●	●	●	●	
8	8				●	●	
9	9		●			●	
A	10				●	●	
B	11		●			●	
C	12			●	●	●	
D	13		●	●	●	●	
E	14		●	●	●	●	
F	15		●	●	●	●	
			4	5	6	7	3

TERM. LOCATION

Available Terminations: A, C, E, S
See fig. 1, page J-26.

NOTE: For terminal location diagram, see page J-26.

C&K S2 Series Subminiature Thumbwheel Switches

TERMINATIONS

S (STD.) PCB

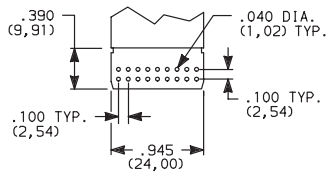

For all function codes except 012.

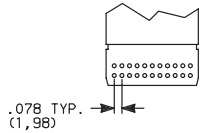

For function code 012.

C PCB WITH SOLDER PINS (HEADER)

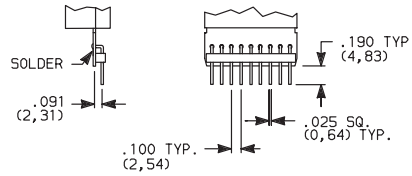

E EXTENDED PCB

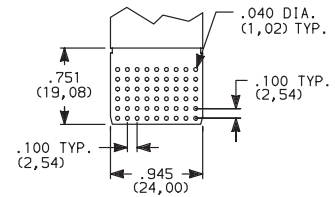

For all function codes except 012.

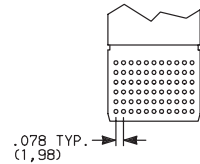

For function code 012.

A EXTENDED PCB WITH PROVISIONS FOR COMPONENTS

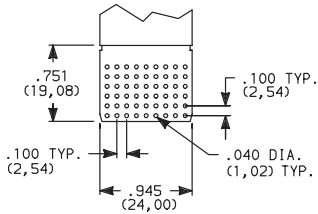

Signal traces cut except for common(s).

L RIGHT ANGLE

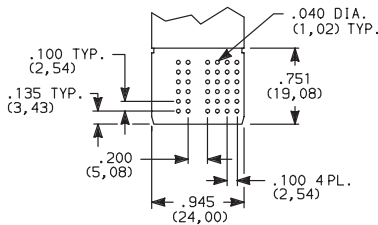

NOTE: PC Board 1/32" (0,79) thick.

P RIGHT ANGLE WITH SOLDER PINS (HEADER)

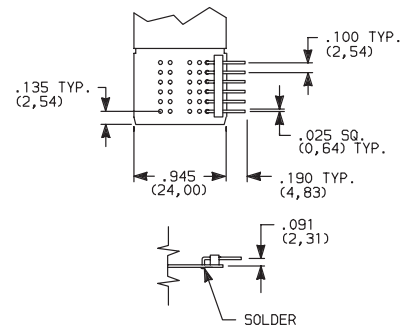

Unsuitable for panel mounting.

Terminal Location Numbers

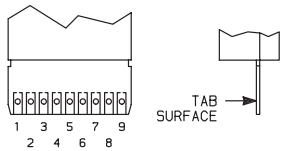

Fig. 1

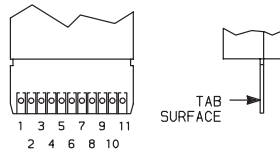

Fig. 2

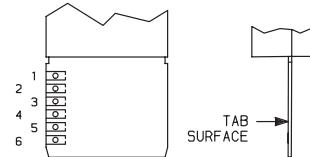

Fig. 3

NOTE: See function codes, pages J-25, for signal locations.

COLOR/MARKING/STOPS

0 (STD.) MATTE BLACK HOUSING (Gloss black wheel with white characters, no stops.)

9 SPECIAL COLORS, MARKINGS FOR HOUSING OR WHEEL, STOPS (Specify on CONFIGURATION FORM, page J-27 and consult Customer Service Center.)

NUMBER OF SECTIONS

0 SWITCH SECTION ONLY no endplates (must be ordered with S2D mounting style, see page J-25.)

1-8 NUMBER OF SWITCH SECTIONS IN ASSEMBLY, includes endplates.

9 MORE THAN 8 SWITCH SECTIONS, specify on CONFIGURATION FORM, page J-27 and consult Customer Service Center.

NOTE: Endplates and blank sections available separately, see section L.

Thumbwheel & Pushwheel

C&K S2 Series Subminiature Thumbwheel Switches

Configuration Form

GRAY SHADED AREAS TO BE FILLED IN BY C&K.

C&K CATALOG PART NO.

S 2

C&K PART NUMBER

C&K PART NUMBER

COMPANY NAME _____











ADDRESS _____ TEL.# _____

CUSTOMER CONTACT _____ DATE _____

ORIGINATED BY _____ SALES REP. _____

CUSTOMER PRINT REVISION:

DETAILS:

THUMBWHEEL SECTIONS	NO. OF SEC.	FUNCTION CODE—TERMINATIONS— COLOR/MARKING/STOPS/SEAL	DESCRIBE IN APPROPRIATE ROW
	1	S 2 - <input type="text"/> <input type="text"/> <input type="text"/> <input type="text"/> <input type="text"/> <input type="text"/> -	
	2	S 2 - <input type="text"/> <input type="text"/> <input type="text"/> <input type="text"/> <input type="text"/> <input type="text"/> -	
	3	S 2 - <input type="text"/> <input type="text"/> <input type="text"/> <input type="text"/> <input type="text"/> <input type="text"/> -	
	4	S 2 - <input type="text"/> <input type="text"/> <input type="text"/> <input type="text"/> <input type="text"/> <input type="text"/> -	
	5	S 2 - <input type="text"/> <input type="text"/> <input type="text"/> <input type="text"/> <input type="text"/> <input type="text"/> -	
	6	S 2 - <input type="text"/> <input type="text"/> <input type="text"/> <input type="text"/> <input type="text"/> <input type="text"/> -	
	7	S 2 - <input type="text"/> <input type="text"/> <input type="text"/> <input type="text"/> <input type="text"/> <input type="text"/> -	
	8	S 2 - <input type="text"/> <input type="text"/> <input type="text"/> <input type="text"/> <input type="text"/> <input type="text"/> -	
	9	S 2 - <input type="text"/> <input type="text"/> <input type="text"/> <input type="text"/> <input type="text"/> <input type="text"/> -	
	10	S 2 - <input type="text"/> <input type="text"/> <input type="text"/> <input type="text"/> <input type="text"/> <input type="text"/> -	
	11	S 2 - <input type="text"/> <input type="text"/> <input type="text"/> <input type="text"/> <input type="text"/> <input type="text"/> -	

ENTER OPTION CODES IN APPROPRIATE BOXES. FUNCTION CODES INCLUDE BLANK SECTIONS (SEE CATALOG PAGE F-17).

QUALITY CONTROL INSTRUCTIONS

PRODUCTION APPROVAL DATE

Q.C. APPROVAL DATE

REV. INITIALS DATE

FOR SWITCHES WITH MORE THAN 11 SECTIONS, CONTINUE ON ADDITIONAL SHEETS.

SPECIAL INSTRUCTIONS OR SPECIFICATIONS:

SHEET ____ OF ____

